

Urbanism and civil engineering: Second-round sample tasks for the Open Doors postgraduate track

You will be asked to complete 30 tasks, including:

- 18 entry-level tasks with one correct answer worth 1-2 points;
- 9 intermediate level tasks with several correct answers worth 3-5 points;
- 3 advanced level tasks (constructed response), each correctly completed tasks valued at 10 points.

Evaluation criteria and standard answers are provided for the advanced tasks requiring constructed responses.

Design and construction of civil buildings

Strength of materials

Task 1 Entry level (1 point)

The joints of two 20-mm diameter bolts is subjected to an axial force. Determine the maximum axial shear stress if $F=45$ kN.

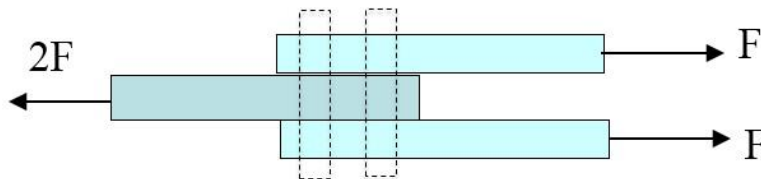

- a) 34.8 MPa
- b) 35.4 MPa
- c) **35.8 MPa**
- d) 36.2 MPa
- e) 36.8 MPa

Answer: c) 35.8 MPa

Task 2 Entry level (2 points)

If the steel shaft it is subjected to torque, determine the angle of twist of gear A with respect to gear D. The diameter of the shaft is 40 mm and the shear modulus of elasticity (G) is 75 GPa.

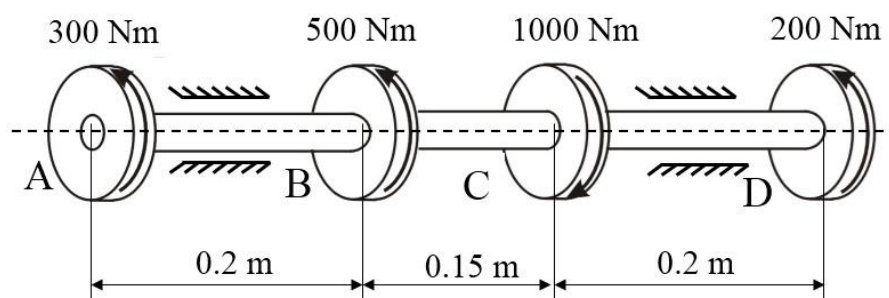

- a) 7.43 rad
- b) 0.743 rad
- c) 0.0743 rad
- d) 0.00743 rad**
- e) 0.000743 rad

Answer: 0.00743 rad

Task 3
Intermediate level (3 points)

Determine the axial force developed in rod AB if the load weight F is 1500 N, $l_2=2l_1$, $E_2=2E_1$, $A_1=2A_2$.

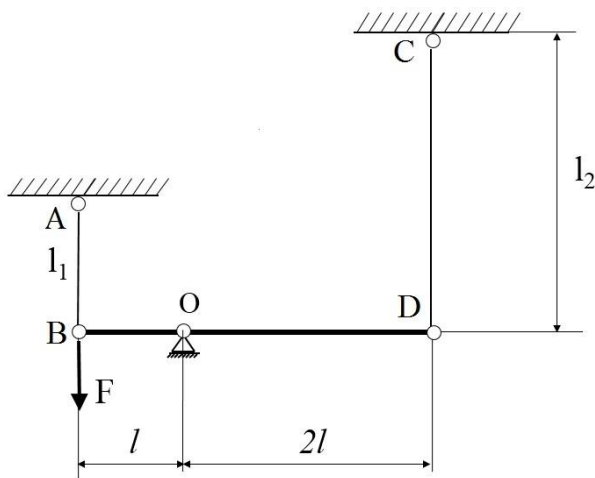

Answer: 500 N.

Task 4
Advanced level (10 points)

The beam is subjected to the loading shown in the figure. Determine the reaction at the support B if $q=10$ kN/m, $M_0=10$ kNm, and $a=1$ m.

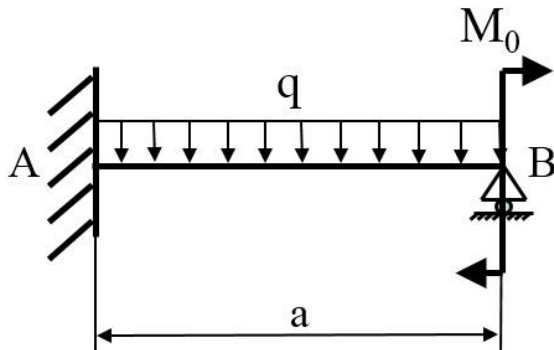

Solution

The support reactions are shown in the figure below. The beam is statically indeterminate.

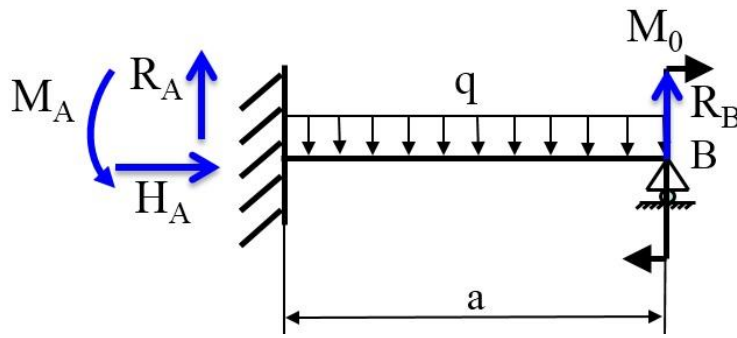

Let us apply the three equations of equilibrium yields:

$$\sum X = 0 \quad H_A = 0$$

$$\sum Y = 0 \quad R_A + R_B - qa = 0$$

$$\sum M_A = 0 \quad R_B a - M_0 - q \frac{a^2}{2} + M_A = 0$$

Let us express the M_A and R_A .

$$M_A = q \frac{a^2}{2} - R_B a + M_0 \text{ and } R_A = qa - R_B.$$

The bending moment of the beam is

$$M(x) = R_A x - M_A - \frac{qx^2}{2}.$$

Then

$$M(x) = qax - R_B x - q \frac{a^2}{2} + R_B a - M_0 - \frac{qx^2}{2}$$

Using a nonlinear second-order differential equation of a beam:

$$EI \frac{d^2 y}{dx^2} = M(x) = qax - R_B x - q \frac{a^2}{2} + R_B a - M_0 - \frac{qx^2}{2}$$

$$EI \frac{dy}{dx} = M(x) = \frac{qax^2}{2} - \frac{R_B x^2}{2} - q \frac{a^2}{2} x + R_B ax - M_0 x - \frac{qx^3}{6} + C$$

$$EIy = M(x) = \frac{qax^3}{6} - \frac{R_B x^3}{6} - \frac{qa^2 x^2}{4} + \frac{R_B ax^2}{2} - M_0 \frac{x^2}{2} - \frac{qx^4}{24} + Cx + D.$$

The unknowns are determined from the boundary conditions

$$x=0 \quad y=0; \quad 0 = 0 - 0 - 0 + 0 - 0 - 0 + D$$

$$x=0; \quad dy/dx=0 \quad 0 = 0 - 0 - 0 + 0 - 0 - 0 + C$$

$$x=a=1 \text{ m } y=0. \quad 0 = \frac{qa^4}{6} - \frac{R_B a^3}{6} - \frac{qa^4}{4} + \frac{R_B a^3}{2} - M_0 \frac{a^2}{2} - \frac{qa^4}{24}.$$

Then,

$$\frac{R_B a^3}{3} = \frac{qa^4}{8} + M_0 \frac{a^2}{2}.$$

$$R_B = 3 \cdot (1.25 + 5) = 18.75 \text{ kN}.$$

Answer: 18.75 kN.

Evaluation criteria:

Correctly developed equations of equilibrium – 3 points.

Correctly developed differential equation of a beam – 6 points.

Completely solved problem – 10 points.

Basics of designing structures, buildings, and facilities

Task 5

Entry level (2 points)

Euler's formula for the critical load for a column pinned at the ends:

1) $P_{cr} = \frac{\pi EJ_{min}}{l^2}$

2) $P_{cr} = \frac{\pi^2 EJ_{min}}{l^2}$

3) $P_{cr} = \frac{\pi^2 EA}{l^2}$

4) $P_{cr} = \frac{\pi^2 EJ_{min}}{l}$

- a) 1
- b) 2**
- c) 3
- d) 4

Answer: b) 2.

Task 6

Entry level (1 points)

Estimate the value of the maximum deflection for a one-span beam

- a) 0.5% - 0.7% of a span**
- b) 3% - 5% of a span
- c) 5% - 10% of a span
- d) 20% - 30% of a span

Answer: a) 0.5% - 0.7% of a span.

Task 7

Entry level (2 points)

What is determined in the stability calculation?

- a) Critical force**
- b) Support reactions
- c) Internal forces
- d) Bending moment
- e) Shear force

Answer: a) Critical force.

Task 8
Entry level (1 points)

How is transverse reinforcement installed in beams?

- a) According to the bending moment diagram - in the tension zone
- b) According to the bending moment diagram - in the compression zone
- c) According to the shear force diagram**
- d) According to the axial force diagram - along the entire length of the structure

Answer: c) According to the shear force diagram.

Urban planning

Task 9
Entry level (2 points)

What type of urban planning scheme is shown in the figure?



- a) Situational plan for the location of the design area**
- b) Territory landscaping plan
- c) Plan of functional zoning of the territory
- d) Master plan of the area

Answer: a) Situational plan for the location of the design area

Task 10
Entry level (2 points)

What is the name of a pedestrian alley with a strip of green space along or in the middle of the street, or along the river bank, intended for walking?

- a) Pedestrian path
- b) Boulevard**
- c) Street
- d) Highway

Answer: b) Boulevard

Task 11
Entry level (1 point)



Cities in which there is one large enterprise (backbone enterprise) are

- a) Industrial cities
- b) Modern cities
- c) **Single-industry towns**
- d) Small towns

Answer: c) Single-industry towns

Task 12
Intermediate level (4 points)

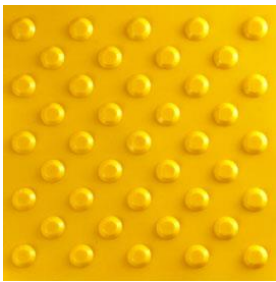
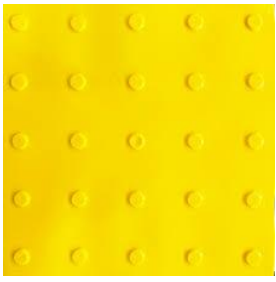
Compare the type of tactile tile for visually impaired people and its description

Pictogram	Meaning
a. 	1. Direction of movement
b. 	2. Change of movement: turn
c. 	3. A surmountable obstacle on the way
d. 	4. An insurmountable obstacle on the way

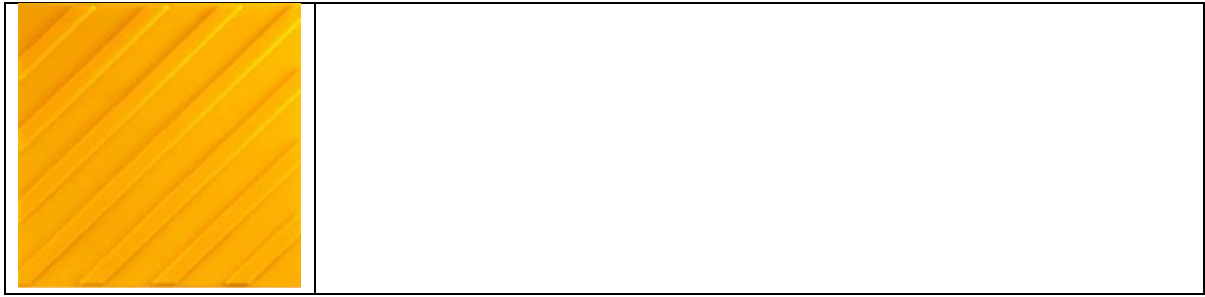

Answer: a – 4, b -3, c -2, d -1

Task 13
Advanced level (10 points)

Dimensions of the plot shown in the figure are $a=50$ m, $b=75$ m. There are two buildings on the plot the dimensions of which are $c=20$ m, $d=30$ m. The buildings are 5 floors high ($f=5$). Road area is $S_{\text{road}}=1200$ m². Determine the Building Coverage Ratio (BCR, %), the Green Plot Ratio (GPR, %) and the Floor Area Ratio (FAR, %).

Note that the evaluation will consider how you solve the task; providing only the final answer is not sufficient.

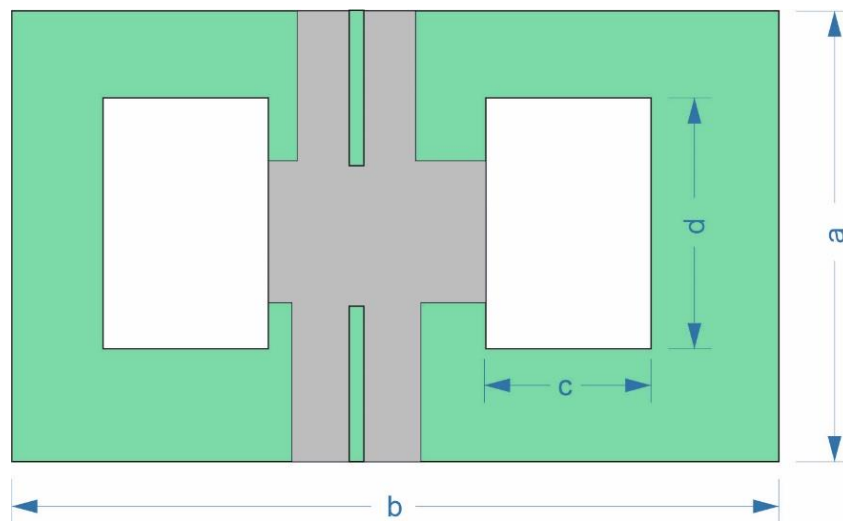

Solution:

Plot area is

$$S_{\text{plot}} = a \cdot b = 50 \cdot 75 = 3750 \text{ m}^2$$

Built-up area is

$$S_{\text{built}} = c \cdot d \cdot 2 = 20 \cdot 30 \cdot 2 = 1200 \text{ m}^2$$

Green area is

$$S_{\text{green}} = S_{\text{plot}} - S_{\text{built}} - S_{\text{road}} = 3750 - 1200 - 1200 = 1350 \text{ m}^2$$

Building Coverage Ratio (%) is

$$\text{BCR} = \frac{S_{\text{built}}}{S_{\text{plot}}} \cdot 100\% = \frac{1200}{3750} \cdot 100\% = 32\%$$

Green Plot Ratio (%) is

$$\text{GPR} = \frac{S_{\text{green}}}{S_{\text{plot}}} \cdot 100\% = \frac{1350}{3750} \cdot 100\% = 36\%$$

Total floor area is

$$S_{\text{floor}} = S_{\text{built}} \cdot f = 1200 \cdot 5 = 6000 \text{ m}^2$$

Floor Area Ratio (%) is

$$\text{FAR} = \frac{S_{\text{floor}}}{S_{\text{plot}}} \cdot 100\% = \frac{6000}{3750} \cdot 100\% = 160\%$$

Answer: BCR=32%, GPR=36%, FAR=160%.

Evaluation criteria:

Correctly determined plot area, built-up area, green area - 5 points.

Correctly determined BCR and GPR – 7 points.

Completely solved problem – 10 points.

Construction technology

Task 14

Entry level (1 points)

What is the primary purpose of using a vapor barrier in building construction?

- a) to provide structural support to walls
- b) to improve the aesthetic appearance of interiors
- c) to prevent moisture from penetrating walls and causing damage**
- d) to enhance the acoustic properties of a building
- e) to increase the load-bearing capacity of the foundation

Answer: c) to prevent moisture from penetrating walls and causing damage

Task 15

Entry level (2 points)

What is a general contractor responsible for?

- a) finish painting and staining.
- b) schedule the construction, recruit the subcontractors, provide payment for them, and oversee the construction.**
- c) cabinet estimating, selections, and drawings.
- d) countertop estimating, fabrication, and installation.
- e) performing electrical wiring and installation.

Answer: b) schedule the construction, recruit the subcontractors, provide payment for them, and oversee the construction.

Task 16
Intermediate level (5 points)

Determine the effective force in the cable P_d for lifting a reinforced concrete beam with a mass of $Q=1.5$ tons according to the diagram shown in the figure. The angle of inclination of the sling to the vertical is $\alpha = 45^\circ$.

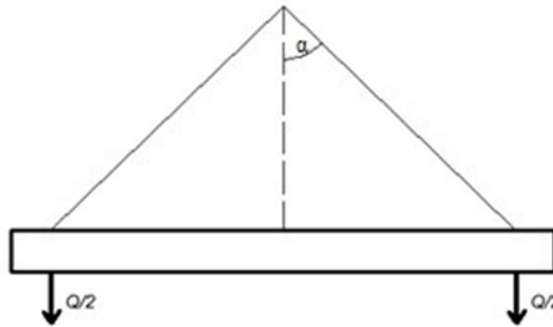

Figure 1. Beam slinging diagram

Answer: 1056 kg

Task 17
Advanced level (10 points)

Determine the volume of earthworks required for digging a trench to lay sewer pipes with an internal diameter of $D = 250$ mm (wall thickness $c = 22$ mm) over a section length $L=200$ m. The trench depth at the start of the section is $h_1=2.20$ m, and at the end, it is $h_2 = 3.10$ m. The trench walls are vertical. According to the requirements for the production and acceptance of construction and installation works, the width of the trench at the bottom should be $D_1 + 0.6$ m, where D_1 – the outer diameter of the pipe.

Note that the evaluation will consider how you solve the task; providing only the final answer is not sufficient.

Solution

Width of the trench at the bottom (a):

1. Determine the outer diameter of the pipe D_1 :
 $D_1=D+2c=250+2\times 22=294$ mm
2. According to the requirements, the width of the trench at the bottom should be $D_1+0.6$ m
 $a=D_1+600=294+600=894$ mm=0.9 m

Cross-sectional areas of the trench:

1. At the start of the trench ($h_1 = 2.20$ m): $F_1=a\cdot h_1 = 0.9 \cdot 2,20 = 1.98$ m²
2. At the end of the trench ($h_2 = 3.10$ m): $F_2=a\cdot h_2 = 0.9 \cdot 3,10 = 2.79$ m²

Volume of the trench:

Using the formula to calculate the volume of the trench considering the depth variation:

$$W_1 = \frac{F_1 + F_2}{2} \cdot L$$

Where:

F_1 – is the cross-sectional area at the start of the trench,

F_2 – is the cross-sectional area at the end of the trench,

L – is the length of the trench.

Substitute the values:

$$W_1 = \frac{1.98 + 2.79}{2} \cdot 200 = 477 m^3$$

Volume occupied by the pipe:

1. Internal volume of the pipe ($V_{internal}$):

$$V_{internal} = \frac{\pi D^2}{4} \cdot L$$

$$V_{internal} = \frac{3.14 \cdot 0.25^2}{4} \cdot 200 = 9.8125 m^3$$

2. Volume of the pipe walls (V_{walls}):

Outer diameter $D_1=0.294$ m

$$V_{walls} = \frac{\pi D^2}{4} \cdot L - V_{внутр}$$

$$V_{walls} = \frac{3.14 \cdot 0.294^2}{4} \cdot 200 - 9.8125 = 3.74 m^3$$

3. Thus, the total volume of the pipe (V_{pipe}):

$$V_{трубы} = V_{internal} + V_{walls} = 9.8125 + 3.74 = 13.55 m^3$$

Final volume of earthworks:

The volume of earthworks is equal to the volume of the trench minus the volume occupied by the pipe:

$$V_{earthworks} = W_1 - V_{pipe} = 477 - 13.55 = 463.45 m^3$$

Answer: 463.45 m³

Evaluation criteria:

Correctly determined cross-sectional areas of the trench – 3 points.

Correctly determined the volume occupied by the pipe – 6 points.

Completely solved problem – 10 points.

Transport systems

Task 18

Entry level (2 point)

Which of the following statements best describes the transport network?

- A system of navigation satellites used to determine the location of vehicles.
- A group of cars owned by the same company.

c) **A system of interconnected roads, railways, waterways and airways designed to move people and goods.**

d) A set of traffic lights and road signs regulating traffic on the roads.

e) The combination of different types of public transport in one city.

Answer: a) A system of interconnected roads, railways, waterways and airways designed to move people and goods.

Task 19

Entry level (2 point)

Which of the following statements best describes public transportation services?

a) Organization of parking lots and garages for private cars.

b) Provision of passenger transportation services by various types of public transport.

c) Development of new car models for personal use.

d) Building and maintaining road infrastructure.

e) Carrying out maintenance and repair of vehicles.

Answer: b) Provision of passenger transportation services by various types of public transport.

Task 20

Entry level (2 point)

Which of the following is a key activity in transportation safety?

a) Installation of automatic fare payment systems.

b) Training drivers in economical driving.

c) The creation of new public transport routes.

d) Improving the comfort of passenger seats.

e) Regular technical inspection and maintenance of vehicles.

Answer: e) Regular technical inspection and maintenance of vehicles.

Task 21

Intermediate level (5 points)

Which of the following functions are key components of Intelligent Transportation Systems (ITS)?

a) Real-time traffic monitoring

b) Selling cars via the Internet

c) Managing traffic lights and road signs based on data

d) Informing drivers about traffic accidents and traffic jams

e) Developing new models of automobile engines

Answer:

a) Real-time traffic monitoring

c) Data-based traffic lights and road signs management

d) Informing drivers about traffic accidents and traffic jams

Mechanics

Structural mechanics

Task 22 Entry level (2 points)

Determine the value of the internal force in kN in rod 6, if it is known that $P=20$ kN, $h=6$ m, $b=5$ m.

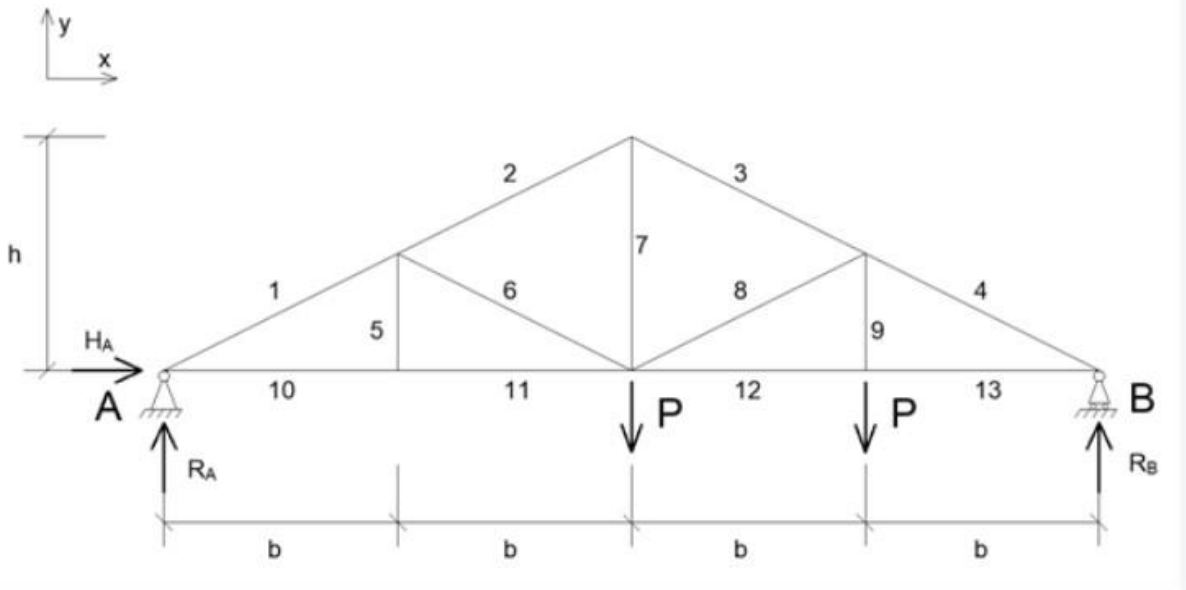

- a) 0
- b) 25
- c) 40
- d) 10

Answer: a) 0

Task 23 Intermediate level (4 points)

Determine the value in kN of the horizontal internal force in hinge C, if it is known that $q=18$ kN/m, $h=4$ m, $a=2$ m.

The answer must be written modulo, in the form of an integer.

For example: when calculating, the value obtained is -18.95 , then the answer must be entered as follows: 19

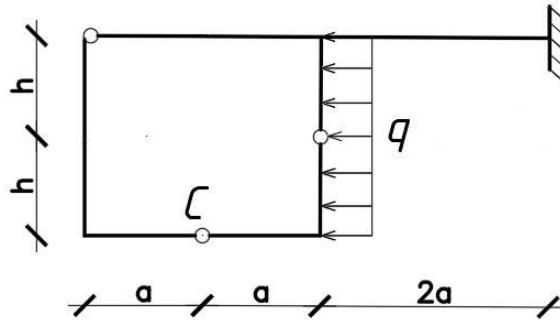

Answer: 12

Task 24
Intermediate level (5 points)

Determine the value of the coefficient δ_{11} in m/kN for a given equivalent state, if it is known that $q=10$ kN/m, $a=3$ m, $b=6$ m, $E=100$ kN · m². The answer must be written modulo and rounded to two decimal places.

For example: when calculating, the number obtained is -5.6553, then the answer must be entered as follows: 5.66

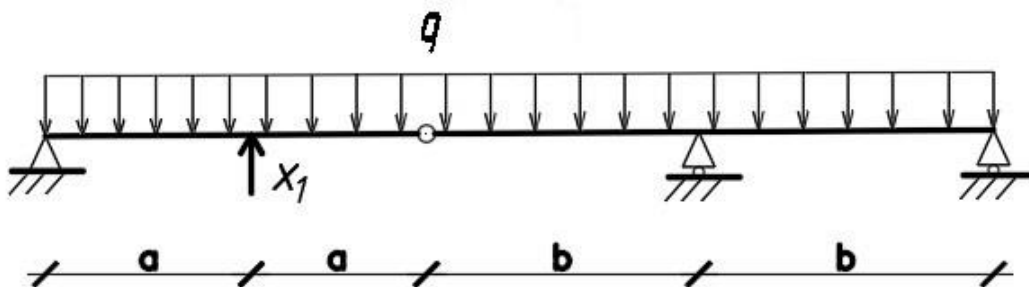

Answer: 0.41 (Note: The range of the correct answer is from 0.39 to 0.43.)

Theory of elasticity

Task 25
Entry level (1 point)

Which of the stress matrix defines the case of uniform simple shear:

$$(\sigma) = \begin{pmatrix} 0 & \tau & 0 \\ \tau & 1 & 1 \\ 0 & 0 & 1 \end{pmatrix}$$

a)

$$(\sigma) = \begin{pmatrix} 0 & \tau & 0 \\ \tau & 0 & 0 \\ 0 & 0 & 0 \end{pmatrix}$$

b)

$$(\sigma) = \begin{pmatrix} 0 & \tau & 6 \\ \tau & 0 & 0 \\ 0 & 0 & 0 \end{pmatrix}$$

c)

$$(\sigma) = \begin{pmatrix} 11 & \tau & 0 \\ \tau & 1 & 0 \\ 0 & 0 & 1 \end{pmatrix}$$

d)

Answer: b)

Task 26
Intermediate level (3 points)

Determine the invariants (the first one, the second one, the third one) of the stress matrix:

$$(\sigma) = \begin{pmatrix} 5 & 0 & 0 \\ 0 & 0 & 0 \\ 0 & 0 & -6 \end{pmatrix}$$

- a) **0**
- b) 1
- c) **-1**
- d) 3
- e) -6
- f) **-30**
- g) -10

Answer: a) 0; c) -1; f) -30

Materials Science – assessment and testing

Task 27
Entry level (1 point)

The ultimate tensile strength of the material is 300 MPa. If the allowable strength is 200 MPa, determine the safety factor.

- a) 1.2
- b) 1.3
- c) 1.4
- d) **1.5**
- e) 1.6

Answer: d) 1.5

Task 28
Entry level (2 point)

The water/cement ratio of some concrete is 0.5. Determine the consumption of cement in 1 m³ concrete if the amount of water is 200 kg.

- a) 380 kg
- b) **400 kg**
- c) 420 kg
- d) 440 kg
- e) 460 kg

Answer: b) 400 kg.

Task 29
Intermediate level (5 point)

The ultimate tensile strength of the roll material is 50 kN/m. Determine the specimen width during testing if the mean breaking load is 5000 N.

Answer: 100 mm.

Task 30
Intermediate level (5 point)

Stress-strain curve for the bar given in the figure. The diameter of the bar is 10 mm. Determine the tensile strength of the bar.

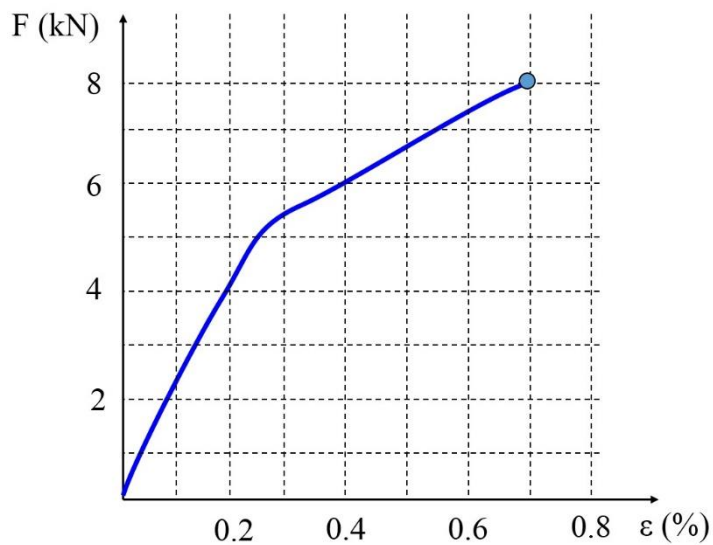

Answer: 102 MPa.